





**PUBLIÉ PAR Lacmé S.A.S.**

Les Pelouses - Route du Lude 72200 LA FLÈCHE

FRANCE

[www.lacme.com](http://www.lacme.com)

TOUS DROITS RÉSERVÉS.

*Notice des électrificateurs 9V de la gamme CLOS*

*11860451 - Édition août 2024*

---



**PUBLISHED BY Lacmé S.A.S.**

Les Pelouses - Route du Lude 72200 LA FLÈCHE

FRANCE

[www.lacme.com](http://www.lacme.com)

ALL RIGHTS RESERVED.

*Instructions for 9V energizers from the CLOS range*

*11860451 - Edition August 2024*

**Clos P-15**

**Clos P-25**

**Clos P-25 V**

**Clos P-35**

---

**FR**

*Vous venez d'acheter un électrificateur Lacmé et nous vous remercions pour votre confiance.*

• **NOTICE D'UTILISATION** ..... **P. 4**

---

**EN**

*You have just purchased a Lacmé energizer and we thank you for your trust.*

• **USER GUIDE** ..... **P. 8**

---

**DE**

*Sie haben gerade ein Lacmé-Elektrozaengerät gekauft und wir danken Ihnen für Ihr Vertrauen.*

• **BEDIENUNGSANLEITUNG** ..... **P. 12**

---

**ES**

*Acaba de comprar un electrificador Lacmé y le agradecemos su confianza.*

• **INSTRUCCIONES DE EMPLEO** ..... **P. 16**

---

**IT**

*Ha appena acquistato un alimentatore di corrente Lacmé e la ringraziamo per la fiducia accordataci.*

• **MANUALE DI ISTRUZIONI** ..... **P. 20**

---

**PT**

*Você acaba de adquirir um energizador Lacmé e agradecemos sua confiança*

• **INSTRUÇÕES DE UTILIZAÇÃO** ..... **P. 24**

---

**LACMÉ**

- Clos P-15**    
  **Clos P-25**    
  **Clos P-25V**    
  **Clos P-35**

**Vous venez d'acheter un électrificateur de clôture Lacmé et nous vous remercions pour votre confiance.**

Il est à alimentation mixte et peut être indifféremment alimenté par :

- une pile 9 V
- un accumulateur 12 V (au plomb au format adapté)
- un accumulateur 12 V (au plomb au format adapté) et l'adaptateur secteur (Réf. : 624.000 - en option)
- l'adaptateur secteur (Réf. : 624.000 - en option) exclusivement fourni par LACMÉ.

Les différents niveaux de puissance et d'options suivant les modèles sont décrits dans cette notice.



**ATTENTION**, une pile ne doit jamais être branchée lorsque l'appareil est alimenté par un adaptateur secteur ou un chargeur

## INSTRUCTIONS IMPORTANTES À CONSERVER :

Ce logo confirme que vous pouvez alimenter votre électrificateur avec un adaptateur secteur.

Seul l'adaptateur secteur fourni en option exclusivement par LACMÉ (Réf. : 624.000) est autorisé sur cet électrificateur. Le raccordement de cet électrificateur à tout autre adaptateur secteur est strictement interdit pour une question de sécurité. L'adaptateur secteur fourni par LACMÉ ne doit pas être utilisé sur un électrificateur concurrent ou sur un ancien et/ou un autre électrificateur de LACMÉ non prévu à cet effet (en cas de doute, vous référer à la notice jointe à votre électrificateur).

La technologie utilisée dite "basse impédance" permet à la clôture de rester efficace même en cas de pertes (herbes qui touchent le fil, isolateurs claqués...).

Cet électrificateur respecte les Normes Internationales de Sécurité et est homologué par le Ministère de l'Agriculture. Il est livré avec un fil de raccordement "Haute Tension" et une petite prise de terre.

## LES DIFFÉRENTS NIVEAUX DE PUISSANCES :

|                   | Alimentation | Énergie max<br>(mJ) | Tension crête<br>Vmax<br>(V) | Consommation |             | Option solaire<br>conseillée<br>(W) | Impulsions/<br>minute<br>(i/min) |
|-------------------|--------------|---------------------|------------------------------|--------------|-------------|-------------------------------------|----------------------------------|
|                   |              |                     |                              | (mA)<br>9V   | (mA)<br>12V |                                     |                                  |
| <b>Clos P-15</b>  | 9V* - 12V    | 150                 | 10500                        | 18           | 12          | 3                                   | 40                               |
| <b>Clos P-25</b>  | 9V* - 12V    | 240                 | 10500                        | 30           | 18          | 3                                   | 40                               |
| <b>Clos P-25V</b> | 9V - 12V     | 50 - 240            | 10500                        | 30           | 18          | 3                                   | 40                               |
| <b>Clos P-35</b>  | 9V* - 12V    | 320                 | 10500                        | 36           | 21          | 3                                   | 40                               |

### CLOS P15

Dimensions : 25 x 19 x 34 cm  
Poids : 3,1 Kg

### CLOS P25/P25V/P354

Dimensions : 25 x 19 x 34 cm  
Poids : 3,2 Kg

*\*Recommandée*

## CONSEILS :

|                   | Types d'animaux    | Longueur clôture (en km) avec végétation : |         |       |
|-------------------|--------------------|--|---------|-------|
|                   |                    | Faible                                     | Moyenne | Forte |
| <b>Clos P-15</b>  | Sensibles/ Dociles | 2  | 0,5     | -     |
| <b>Clos P-25</b>  | Faciles/ Dressés   | 3  | 1       | -     |
| <b>Clos P-25V</b> | Faciles/ Dressés   | 3  | 1       | -     |
| <b>Clos P-35</b>  | Faciles/ Dressés   | 4  | 1,5     | 0,5   |

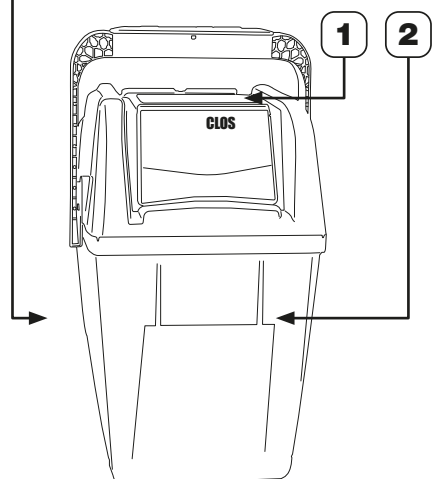
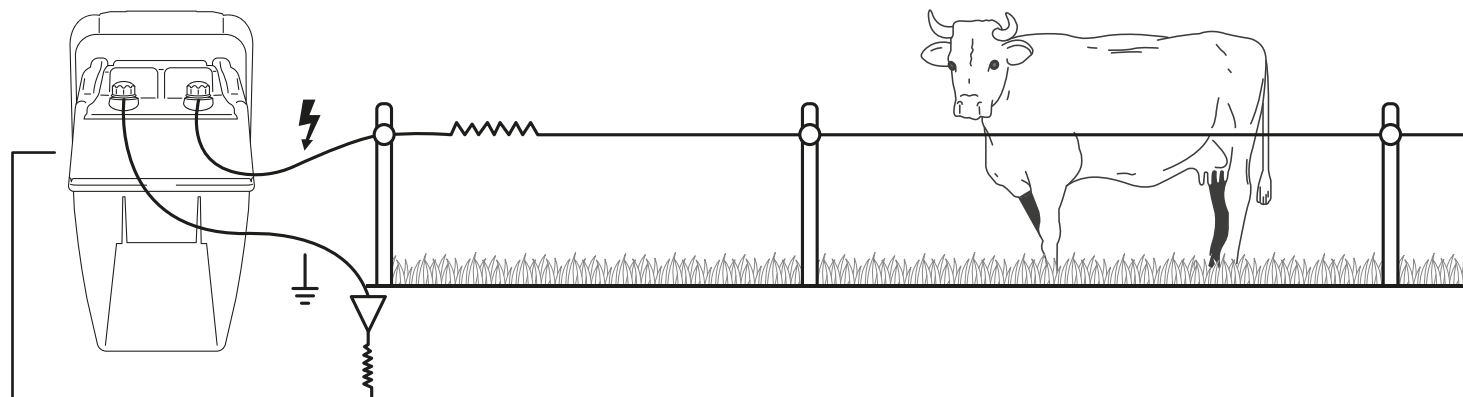

- 1 Tête
- 2 Bac accu-pile

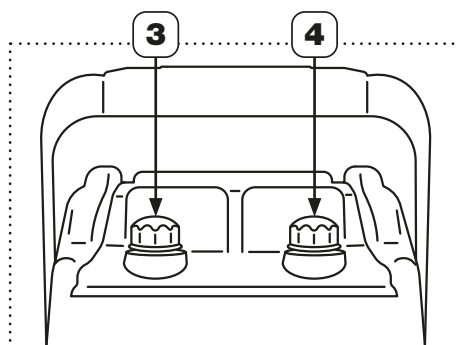

Face arrière du poste

- 3 Branchement prise de terre
- 4 Branchement fil de clôture

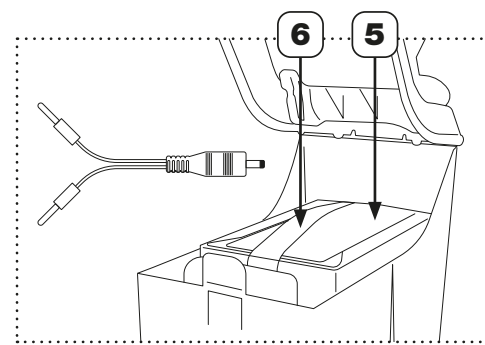

Dessous du couvercle

- 5 Branchement sur pile 9V  
↳ Connecter le fil rouge sur le rouge et fil noir sur le noir



**ATTENTION**, en cas d'alimentation par pile 9V l'étiquette 6 doit être complètement retirée pour que la combustion de la pile puisse se faire

6



Alimentation par batterie possible, veiller à respecter la polarisation.

**INDICATIONS DE FONCTIONNEMENT** ☑ **CLOS P-15**

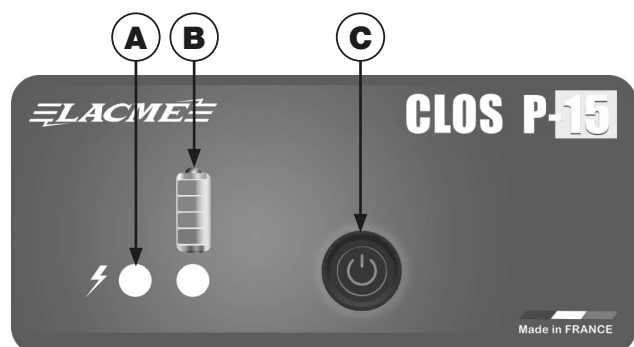

Lexan situé sur le dessus du poste

- A • Témoin de fonctionnement
- B • Indicateur pile/batterie faible
- C • Bouton Marche/Arrêt



**INDICATIONS DE FONCTIONNEMENT**  **CLOS P-25 V**

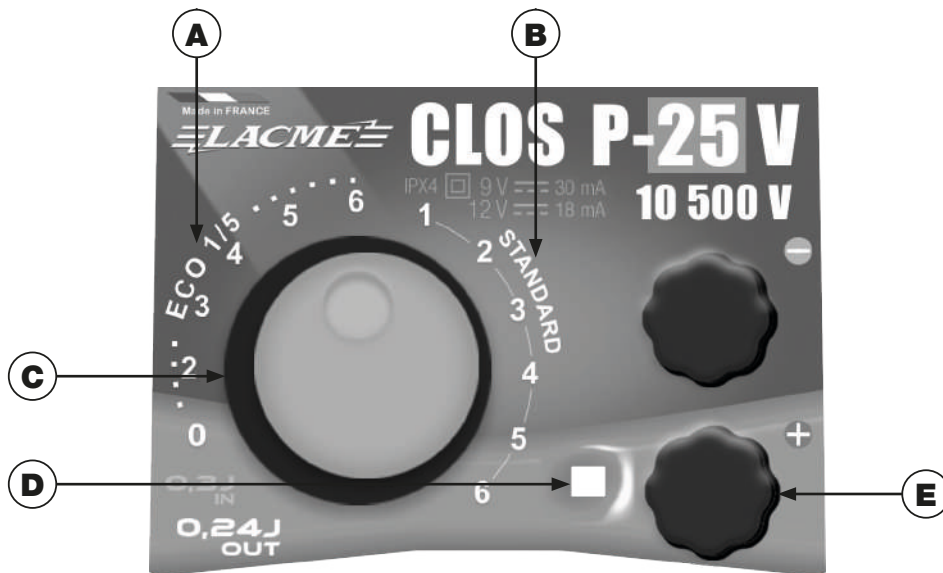

- D**
- ✓ **LED VERTE :**  
OK.
  - ✓ **LED ORANGE :**  
à surveiller.
  - ✓ **LED ROUGE :**  
charger impérativement  
la batterie.

- A** • Impulsions Eco 1/5
- B** • Impulsions Standard
- C** • Variateur de puissance  
• Marche/Arrêt
- D** • Voyant de fonctionnement  
• Affichage charge batterie
- E** • Branchement panneau solaire

**INDICATIONS DE FONCTIONNEMENT**  **CLOS P-25**  **CLOS P-35**

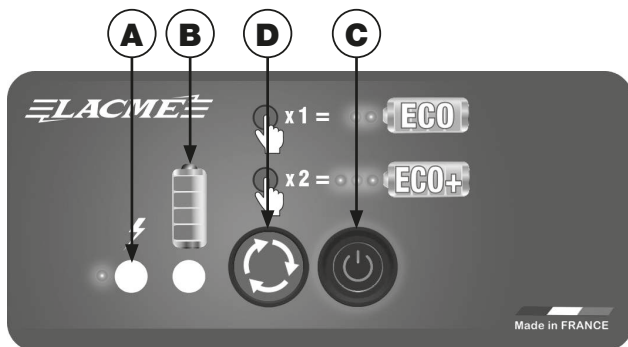

*Lexan situé sur le dessus du poste*

- A** • Témoin de fonctionnement
- B** • Indicateur pile/batterie faible
- C** • Bouton Marche/Arrêt
- D** • Modes ÉCO ou ÉCO+



**ATTENTION**, pour tous les électrificateurs, toujours recharger un accu le plus tôt possible en zone rouge. Pour une pile, l'échange peut attendre la décharge complète.

**LES FONCTIONS**  **CLOS P-15**



**INTERRUPTEUR  
MARCHÉ / ARRÊT**



**VOYANT DE CONTRÔLE :**

• Sur le capot, un voyant de contrôle témoigne du bon fonctionnement lors de chaque impulsion.

## LES FONCTIONS CLOS P-25 V



### VARIATEUR DE PUISSANCE :

• Le variateur permet de régler la puissance en fonction des besoins (type d'animaux, longueur de clôture, isolement, humidité...), et en particulier de réduire la consommation dès que la période de dressage des animaux est terminée.



### MODE STANDARD OU ECO 1/5 :

• Il existe deux modes de fonctionnement :

**A** Le mode standard

**B** Le mode économique : "ECO 1/5", : il suffit de placer le variateur sur une des valeurs de la plage correspondant à la zone "ECO 1/5". L'électrificateur répète un cycle de 5 impulsions : la première est de puissance déterminée par le variateur, les 4 autres sont de puissance réduite.



### VOYANT CHARGE PILE/BATTERIE :

• Sur la face avant, un voyant de contrôle batterie témoigne de la décharge de l'alimentation. **Cette lampe témoin a 3 couleurs (vert, orange, rouge).**



### TECHNOLOGIE ACCU PROTECT :

• Lorsque l'alimentation est trop déchargée, la technologie **ACCU PROTECT** bascule automatiquement l'appareil en mode "ECO 1/5".

## LES FONCTIONS CLOS P-25 CLOS P-35



### INTERRUPTEUR MARCHÉ / ARRÊT



### INDICATEUR DE CHARGE PILE / BATTERIE FAIBLE



### TECHNOLOGIE ACCU PROTECT :

• Lorsque l'alimentation est trop déchargée, la technologie **ACCU PROTECT** bascule automatiquement l'appareil en mode "ECO 1/5".



### MODES STANDARD, ÉCO ou ÉCO+ :



**Appui 1** : Passage en mode **ÉCO** (autonomie x2) ; La LED de fonctionnement clignote 2 fois



**Appui 2** : Passage en mode **ÉCO+** (autonomie x3) ; La LED de fonctionnement clignote 3 fois



**Appui 3** : Passage en mode **STANDARD** ; La LED de fonctionnement clignote 1 fois

**Clos P-15**    
  **Clos P-25**    
  **Clos P-25V**    
  **Clos P-35**

**You have purchased a fence energizer Lacmé. We thank you for your trust.**

It is a fencing energizer with a mixed power supply. Its power can be supplied equally well by :

- 9 V battery (not included)
- a 12 V wet cell battery (lead, in a suitable format) (not included)
- a 12 V wet cell battery (lead, in a suitable format) and the mains adaptor ( Réf. : 624.000 - optional)
- the mains adaptor ( Réf. : 624.000 - optional) exclusively supplied by LACMÉ.

Different power levels and options depending on the model are described in this notice.



**CAUTION**, the use of a battery and the adapter together is dangerous and therefore prohibited.

**IMPORTANT INSTRUCTIONS TO SAVE :**

This logo confirms that you can power your energiser with an AC adaptor.

Only the mains adaptor exclusively supplied by LACMÉ ( Réf. : 624.000) is optionally allowed on this energizer.

For safety reasons, this energizer must never be connected to any other mains adaptor. The mains adaptor supplied by LACMÉ must not be used on an energizer from another manufacturer, or on any old/other LACMÉ model not designed for this purpose (if in doubt, refer to the guide provided with your energizer).

The technology called "low impedance" allows the fence to remain effective even if losses occur grass touching the wire, broken insulators...).

This energizer conforms to International Safety Standards and is approved by the French Ministry of Agriculture. It is supplied with a high voltage wire connection and a small earth/ground rod connection.

**DIFFERENT POWER LEVELS :**

|                   | Power supply | Max energy<br>(mJ) | Peak voltage Vmax<br>(V) | Consumption |             | Recommended solar option<br>(W) | Pulses/minute<br>(i/min) |
|-------------------|--------------|--------------------|--------------------------|-------------|-------------|---------------------------------|--------------------------|
|                   |              |                    |                          | (mA)<br>9V  | (mA)<br>12V |                                 |                          |
| <b>Clos P-15</b>  | 9V* - 12V    | 150                | 10500                    | 18          | 12          | 3                               | 40                       |
| <b>Clos P-25</b>  | 9V* - 12V    | 240                | 10500                    | 30          | 18          | 3                               | 40                       |
| <b>Clos P-25V</b> | 9V - 12V     | 50 - 240           | 10500                    | 30          | 18          | 3                               | 40                       |
| <b>Clos P-35</b>  | 9V* - 12V    | 320                | 10500                    | 36          | 21          | 3                               | 40                       |

**CLOS P15**

L x W x H : 25 x 19 x 34 cm  
Weight : 3,1 Kg

**CLOS P25/P25V/P354**

L x W x H : 25 x 19 x 34 cm  
Weight : 3,2 Kg

*\*Recommended*

**ADVICE :**

|                   | Animal Type       | Fences up to (km) with vegetation : |        |        |
|-------------------|-------------------|-------------------------------------|--------|--------|
|                   |                   | Weak                                | Medium | Strong |
| <b>Clos P-15</b>  | Sensitive, docile | 2                                   | 0,5    | -      |
| <b>Clos P-25</b>  | Docile, trained   | 3                                   | 1      | -      |
| <b>Clos P-25V</b> | Docile, trained   | 3                                   | 1      | -      |
| <b>Clos P-35</b>  | Docile, trained   | 4                                   | 1,5    | 0,5    |

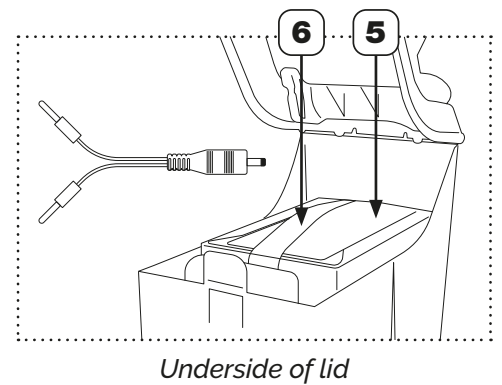
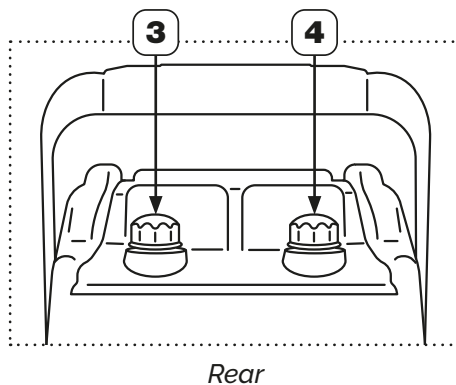
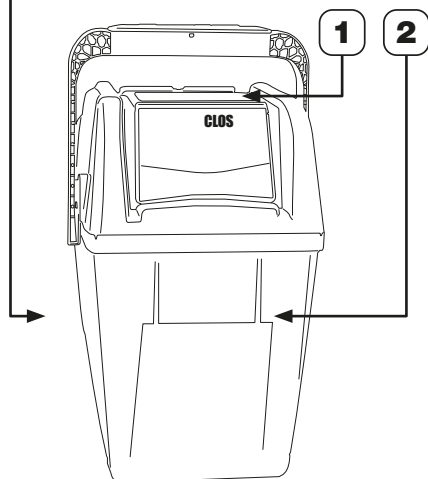
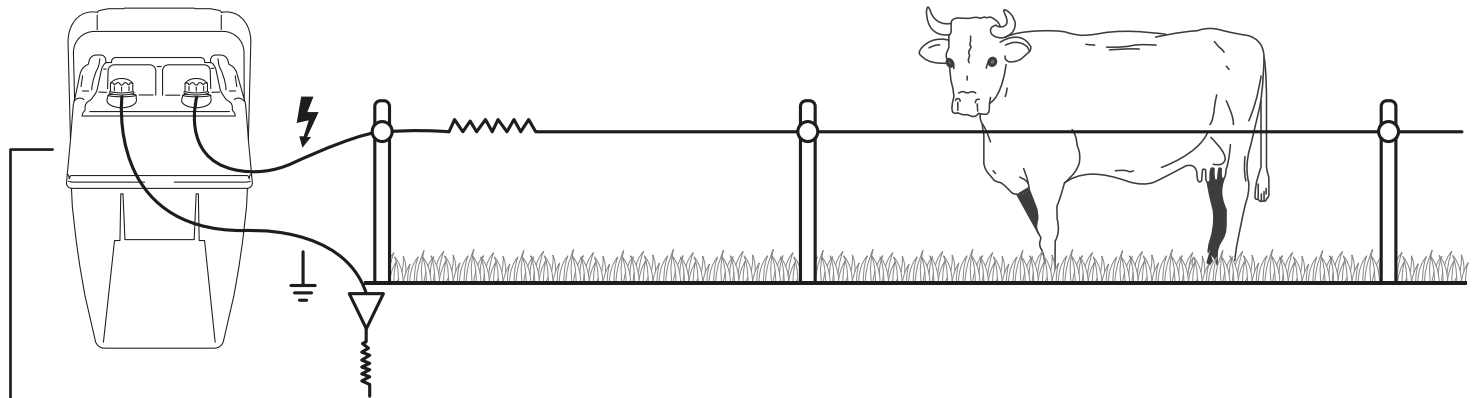

- 1** Head
- 2** Accumulator/ battery container

- 3** Earthing connexion
- 4** Fence connexion

- 5** Connection to **battery 9V**  
↳ Connect : red wire on red / black wire on black



**WARNING**, if powered by a 9V battery, the label **6** must be completely removed so that the battery can burn.



Battery powered possible, make sure to respect the polarization.

**OPERATING INDICATIONS**

**CLOS P-15**

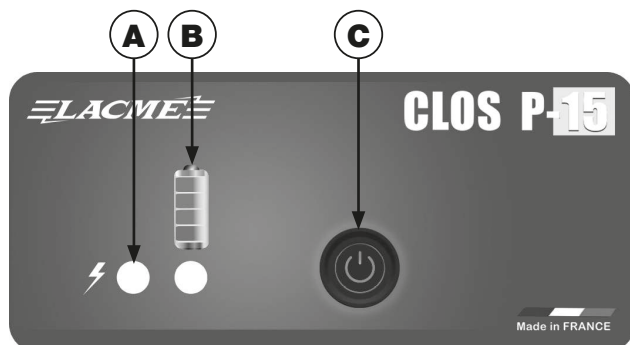

- A** • Led "in use" indicator light
- B** • Indicator low battery
- C** • Switch ON/OFF



Lexan located on top of the post

## OPERATING INDICATIONS

☑ **CLOS P-25 V**



- ✓ **GREEN LED :**  
OK.
- ✓ **ORANGE LED :**  
to monitor.
- ✓ **RED LED :**  
charge the battery.

- A** • Impulses Eco 1/5
- B** • Standard impulses
- C** • Power value  
• Switch ON/OFF
- D** • Led "in use"  
indicator light  
• Display of the battery charge
- E** • Solar panel connection

## OPERATING INDICATIONS

☑ **CLOS P-25**

☑ **CLOS P-35**

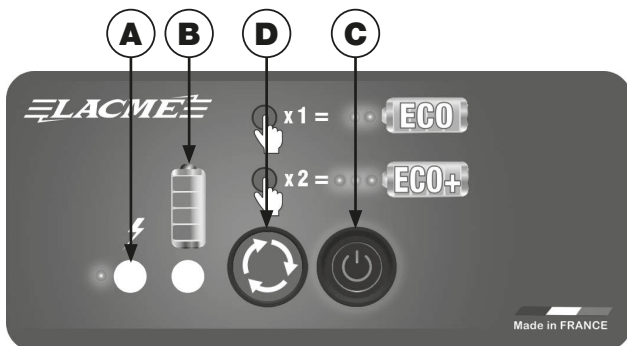

*Lexan located on top of the post*

- A** • Control Display
- B** • Indicator low battery
- C** • Switch ON/OFF
- D** • ÉCO ou ÉCO+ modes



**WARNING.** For all devices, always recharge a wet cell battery that is in the red zone as soon as possible. For a battery, the exchange can wait until it is fully discharged.

## FEATURES ☑ **CLOS P-15**



**SWITCH ON/OFF**



**CONTROL DISPLAY :**

• On the top, a control display indicates the state of operation after each pulse.

## FEATURES CLOS P-25 V



### POWER VALUE :

• A power output control adjusts the output power according to requirements (depending on the type of animal, length of the fencing, insulation, humidity, etc.). And in particular enables power consumption to be reduced as soon as the animal training stage is completed.



### STANDARD OR ECO 1/5 MODES :

• It has two operating modes :

➊ Standard mode

➋ Economy mode : "ECO 1/5", : all you have to do is set the variator to one of the values of the range corresponding to the "ECO 1/5" zone. The energizer repeats a cycle of 5 pulses : the power of the first is determined by the variator, the 4 others have a reduced power.



### BATTERY CHARGE INDICATOR :

• On the front panel, a battery charge indicator light indicates the power supply discharge. **This indicator light has 3 colours (green, orange, red).**



### ACCU PROTECT TECHNOLOGY :

• When the power supplied to the energizer becomes too low **ACCU PROTECT** automatically switches the device into "ECO 1/5" mode.

## FEATURES CLOS P-25 CLOS P-35



### SWITCH ON/OFF



### LOW BATTERY INDICATOR



### ACCU PROTECT TECHNOLOGY :

• When the power supplied to the energizer becomes too low, **ACCU PROTECT** automatically switches the device into "ECO" mode.



### STANDARD, ECO OR ECO+ MODES :



**First push : ECO mode** (autonomy x2) ; The Led blinking twice



**Second push : ECO+ mode** (autonomy x3) ; The Led blinking three time

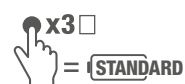

**Third push : STANDARD Impulse ;** The Led blinking once

- Clos P-15**    
  **Clos P-25**    
  **Clos P-25V**    
  **Clos P-35**

**Wir gratulieren Ihnen zum Kauf dieses Lacmé-Weidezaungeräts. Vielen Dank für Ihr Vertrauen.**

Das Weidezaungerät verfügt über eine duale Stromversorgung. Dies ermöglicht, die folgenden verschiedenen Versorgungsarten :

- 9 V-Batterie (nicht enthalten)
- 12 V-Akku (Bleiakku im entsprechenden Format) (nicht enthalten)
- 12 V-Akku (Bleiakku im entsprechenden Format) und LACMÉ-Netzteil ( Réf. : 624.000 - Option)
- LACMÉ-Netzteil ( Réf. : 624.000 - Option).

In dieser Anleitung werden die verschiedenen Leistungsniveaus und Optionen je nach Modell beschrieben.



**WARNUNG.** Ein Netzadapter darf keinesfalls gleichzeitig mit 9V-Batterie verwendet werden. Das ist gefährlich und daher verboten.

## WICHTIGE HINWEISE ZUM SPEICHERN :

Dieses Logo bestätigt, dass Sie Ihr Elektrozaungerät mit einem Netzadapter betreiben können.

Ausschließlich das LACMÉ-Netzteil ( Réf. : 624.000) darf mit diesem Weidezaungerät optional verwendet werden. Aus Sicherheitsgründen darf das Weidezaungerät keinesfalls mit einem anderen Netzteiltypen verwendet werden. Das LACMÉ-Netzteil darf keinesfalls mit Weidezaungeräten eines anderen Herstellers oder mit älteren und/oder anderen Weidezaun-Gerätemodellen von LACMÉ, die dafür nicht vorgesehen sind (im Zweifelsfall bitte in der Bedienungsanleitung Ihres Weidezaungerätes nachlesen), verwendet werden.

Die verwendete Niedrigimpedanztechnologie sorgt dafür, daß der Zaun auch bei Stromverlusten (Grasbewuchs, durchgebrannte Isolatoren, usw.) wirksam bleibt.

Dieses Modell entspricht den internationalen Sicherheitsvorschriften und ist vom Landwirtschaftsministerium zugelassen. Es wird mit einer Hochspannungsverbindungsblitze und einem kleinem Erdstecker geliefert.

## DIE VERSCHIEDENEN LEISTUNGSSTUFEN :

|                   | Stromversorgung | Maximale Energie (mJ) | Spitzenspannung Vmax (V) | Energieverbrauch |          | Empfohlene Solaroption (W) | Impulse/Minute (i/min) |
|-------------------|-----------------|-----------------------|--------------------------|------------------|----------|----------------------------|------------------------|
|                   |                 |                       |                          | (mA) 9V          | (mA) 12V |                            |                        |
| <b>Clos P-15</b>  | 9V* - 12V       | 150                   | 10500                    | 18               | 12       | 3                          | 40                     |
| <b>Clos P-25</b>  | 9V* - 12V       | 240                   | 10500                    | 30               | 18       | 3                          | 40                     |
| <b>Clos P-25V</b> | 9V - 12V        | 50 - 240              | 10500                    | 30               | 18       | 3                          | 40                     |
| <b>Clos P-35</b>  | 9V* - 12V       | 320                   | 10500                    | 36               | 21       | 3                          | 40                     |

### CLOS P15

Dimensionen : 25 x 19 x 34 cm  
Gewicht : 3,1 Kg

### CLOS P25/P25V/P354

Dimensionen : 25 x 19 x 34 cm  
Gewicht : 3,2 Kg

*\*Empfohlen*

## UNSERE EMPFEHLUNG :

|                   | Tierarten            | Zaunlänge (km) mit Bewuchs : |        |       |
|-------------------|----------------------|------------------------------|--------|-------|
|                   |                      | Leicht                       | Mittel | Stark |
| <b>Clos P-15</b>  | Empfindlich, folgsam | 2                            | 0,5    | -     |
| <b>Clos P-25</b>  | Folgsam, dressiert   | 3                            | 1      | -     |
| <b>Clos P-25V</b> | Folgsam, dressiert   | 3                            | 1      | -     |
| <b>Clos P-35</b>  | Folgsam, dressiert   | 4                            | 1,5    | 0,5   |

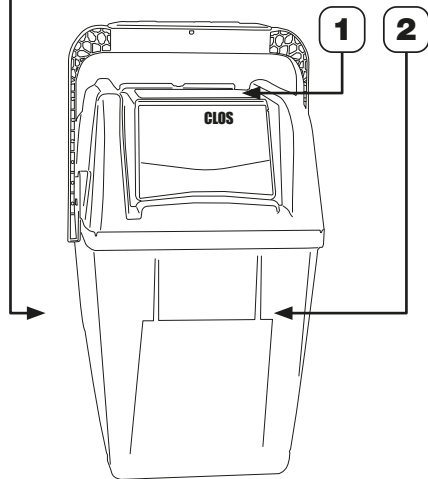
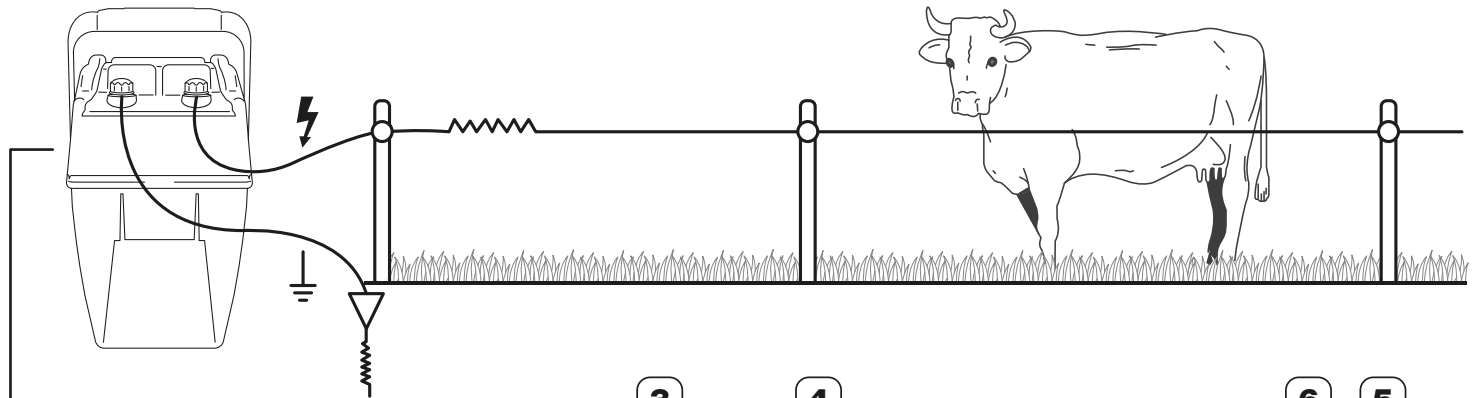

1 Gerätekopf 2 Batteriefach

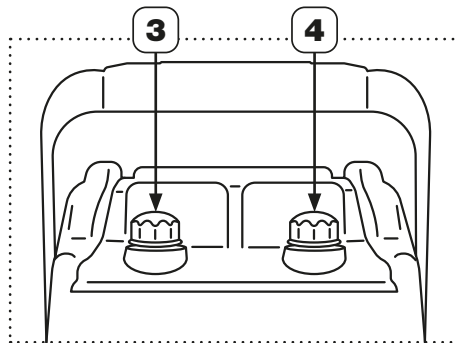

Rückseite

- 3 Anschluss Erdungsdraht
- 4 Anschluss Zaundraht

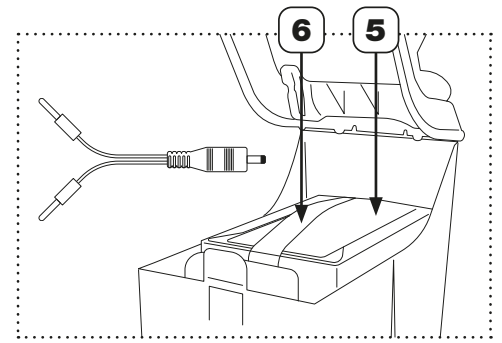

Unterseite des Deckels

- 5 Anschluss an Einem 9 V-Batterie  
↳ Verbinden Sie : das rote Batterieanschlusskabel mit dem roten Anschluss / das schwarze Batterieanschlusskabel mit dem schwarzen Anschluss



**ACHTUNG.** Bei Betrieb mit einer 9-V-Batterie muss das Etikett 6 vollständig entfernt werden, damit die Batterie durchbrennen kann.

6



Batteriebetrieb möglich, Achten Sie darauf, die Polarisierung.

**BETRIEBSANZEIGEN**

CLOS P-15

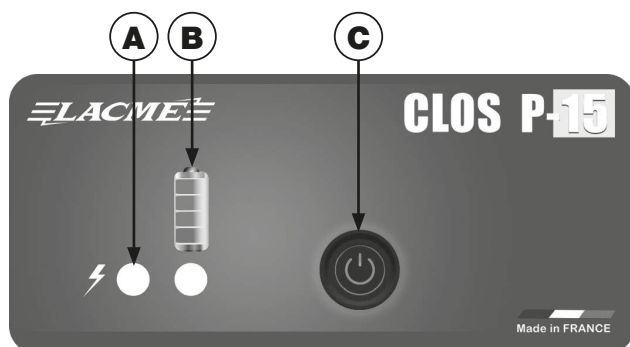

- A • Betriebsanzeige-LED
- B • Indikator Batterie schwach
- C • Ein/AUS-SCHALTER

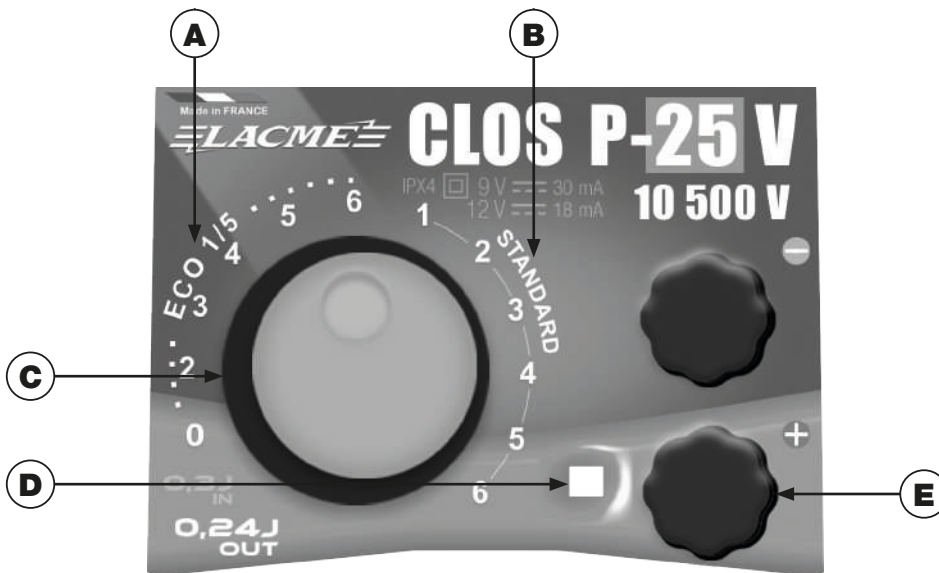

Lexan befindet sich oben auf dem Pfosten

**BETRIEBSANZEIGEN**☑ **CLOS P-25 V**

- ✓ **GRÜNE LED** : OK.
- ✓ **ORANGEFARBENE LED** : zu überwachen.
- ✓ **ROTE LED** : lade die Batterie auf.

- A** • Eco-Modus
- B** • Standard-Modus
- C** • Leistungsregler  
• Aus-Schalter
- D** • Betriebsanzeige-LED  
• Batterieladestand-Anzeige
- E** • Anschluss Solarpanel

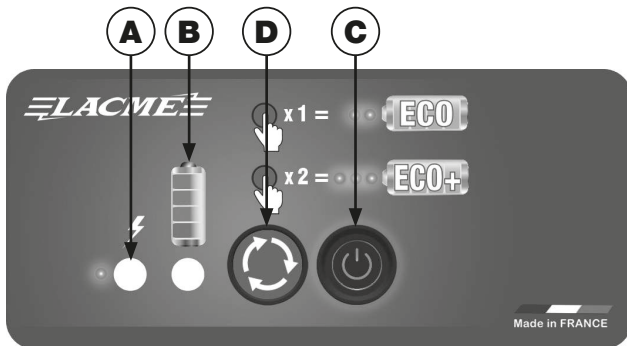
**BETRIEBSANZEIGEN**☑ **CLOS P-25**☑ **CLOS P-35**

*Lexan befindet sich oben auf dem Pfosten*

- A** • Kontrollleuchte
- B** • Indikator  
Batterie schwach
- C** • Aus-Schalter
- D** • ÉCO-Modus oder  
ÉCO+-Modus



**WARNUNG**, Laden Sie bei allen Geräten, Akkus müssen so schnell wie möglich aufgeladen werden, sobald die rote Kontrollleuchte brennt. Batterien können vor dem Auswechseln vollständig geleert werden.

**FUNKTIONEN**☑ **CLOS P-15**

**EIN /  
AUS-SCHALTER**

**KONTROLLLEUCHE :**

• Eine Kontrollleuchte auf der oben drauf um den korrekten Betrieb des Gerätes anzuzeigen.

## FUNKTIONEN

☑ **CLOS P-25 V**



### IMPULS-REGLER :

• Sein Regler ermöglicht eine bedarfsorientierte Einstellung der Leistung (je nach Tierart, Zaunlänge, Isolierung, Feuchtigkeit usw.) und die Umstellung auf sparsamen Verbrauch nach Beendigung der Dressurzeit.



### STANDARD ODER ECO 1/5 MODUS :

• Man unterscheidet zwei Betriebsarten :

Ⓐ Standard-modus

Ⓑ Eco-modus : "ECO 1/5", : Es genügt, den Leistungsregler auf einen der Werte des Bereiches zu positionieren, der dem Bereich "ECO 1/5" entspricht. Das Elektrozaungerät wiederholt einen Zyklus von 5 Impulsen : Die Leistung des ersten Impulses wird durch den Leistungsregler bestimmt. Die 4 anderen Impulse haben eine reduzierte Leistung.



### BATTERIEANZEIGE :

• Auf der Vorderseite wird über eine Akku-Kontrollleuchte der Ladezustand der Stromquelle angezeigt. **Diese Kontrollleuchte ist 3-farbig (grün, orange, rot).**



### ACCU PROTECT-SYSTEM :

• Bei zu schwacher Batterie- oder Akkuladung schaltet das **ACCU PROTECT**-System automatisch auf "ECO 1/5"-Sparbetrieb um.

## FUNKTIONEN

☑ **CLOS P-25**

☑ **CLOS P-35**



### EIN / AUS-SCHALTER



### ANZEIGE FÜR NIEDRIGEN BATTERIESTAND



### ACCU PROTECT-SYSTEM :

• Bei zu schwacher Batterie- oder Akkuladung schaltet das **ACCU PROTECT**-System automatisch auf "ECO"-Sparbetrieb um.



### STANDARD, ECO ODER ECO+ MODUS :



**Einmal drücken : Eco Modus**  
(Autonomie x2) ; Das Licht einmal blinken



**Zweimal drücken : Eco+ Modus**  
(Autonomie x3) ; Das Licht zweimal blinken

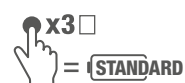

**Dritter drücken : Standard Impulse** ; Das Licht einmal blinken

- Clos P-15**    
  **Clos P-25**    
  **Clos P-25V**    
  **Clos P-35**

### Acaba de comprar una cerca electrificada y le agradecemos su confianza.

Es un electrificador de cercado de alimentación mixta. Puede ser alimentado indistintamente por :

- una pila 9 V
- un acumulador de 12 V (en plomo con formato adaptado)
- un acumulador de 12 V (en plomo con formato adaptado) y el adaptador de corriente (Réf. : 624.000 - opcional)
- el adaptador de corriente ( Réf. : 624.000 - opcional) suministrado exclusivamente por LACMÉ

En esta nota se describen los diferentes niveles de potencia y de opciones según los modelos..

**TOQUE DE ATENCIÓN**, : la utilización conjunta de una pila y un adaptador es peligrosa luego prohibida.

### INSTRUCCIONES IMPORTANTES PARA AHORRAR :

Este logotipo confirma que se puede alimentar el energizador con un adaptador de red.

Le adaptador de corriente LACMÉ (Réf. : 624.000) es el único autorizado para este electrificador. Por razones de seguridad, la conexión de este electrificador a cualquier otro adaptador está estrictamente prohibida. El adaptador de corriente suministrado por LACMÉ no debe utilizarse con un electrificador de otra marca ni con un modelo antiguo de electrificador LACMÉ no previsto para tal efecto (en caso de duda, remitase a las instrucciones entregadas con le electrificador).

La tecnología empleada llamada "baja impedancia" permite que la cerca siga siendo eficaz aún en caso de pérdidas (hierbas que tocan el alambre, aislantes rotos,...).

Este aparato cumple con las Normas Internacionales de Seguridad y ha sido homologado por el Ministerio de Agricultura. Se entrega con un alambre "alta tensión" y una toma de tierra.

### LOS DIFERENTES NIVELES DE POTENCIA :

|                   | Alimentación | Energía máxima<br>(mJ) | Voltaje pico<br>Vmax<br>(V) | Consumo    |             | Opción solar<br>recomendada<br>(W) | Pulsos/minuto<br>(i/min) |
|-------------------|--------------|------------------------|-----------------------------|------------|-------------|------------------------------------|--------------------------|
|                   |              |                        |                             | (mA)<br>9V | (mA)<br>12V |                                    |                          |
| <b>Clos P-15</b>  | 9V* - 12V    | 150                    | 10500                       | 18         | 12          | 3                                  | 40                       |
| <b>Clos P-25</b>  | 9V* - 12V    | 240                    | 10500                       | 30         | 18          | 3                                  | 40                       |
| <b>Clos P-25V</b> | 9V - 12V     | 50 - 240               | 10500                       | 30         | 18          | 3                                  | 40                       |
| <b>Clos P-35</b>  | 9V* - 12V    | 320                    | 10500                       | 36         | 21          | 3                                  | 40                       |

#### CLOS P15

Dimensiones : 25 x 19 x 34 cm  
Peso : 3,1 Kg

#### CLOS P25/P25V/P354

Dimensiones : 25 x 19 x 34 cm  
Peso : 3,2 Kg

\*Recomendado

### CONSEJO :

|                   | Animales             | Longitud cerca (km) con vegetación : |       |       |
|-------------------|----------------------|--------------------------------------|-------|-------|
|                   |                      | Débil                                | Media | Mucha |
| <b>Clos P-15</b>  | Sensibles, dóciles   | 2                                    | 0,5   | -     |
| <b>Clos P-25</b>  | Dóciles, adiestrados | 3                                    | 1     | -     |
| <b>Clos P-25V</b> | Dóciles, adiestrados | 3                                    | 1     | -     |
| <b>Clos P-35</b>  | Dóciles, adiestrados | 4                                    | 1,5   | 0,5   |

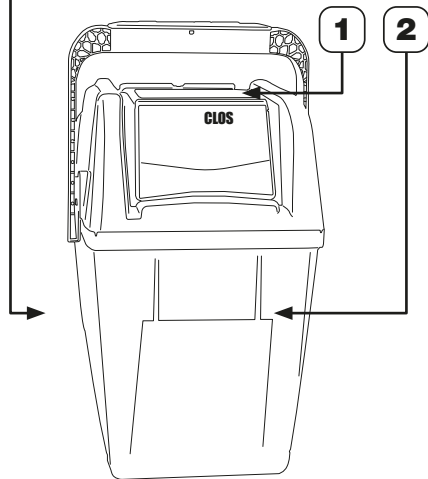
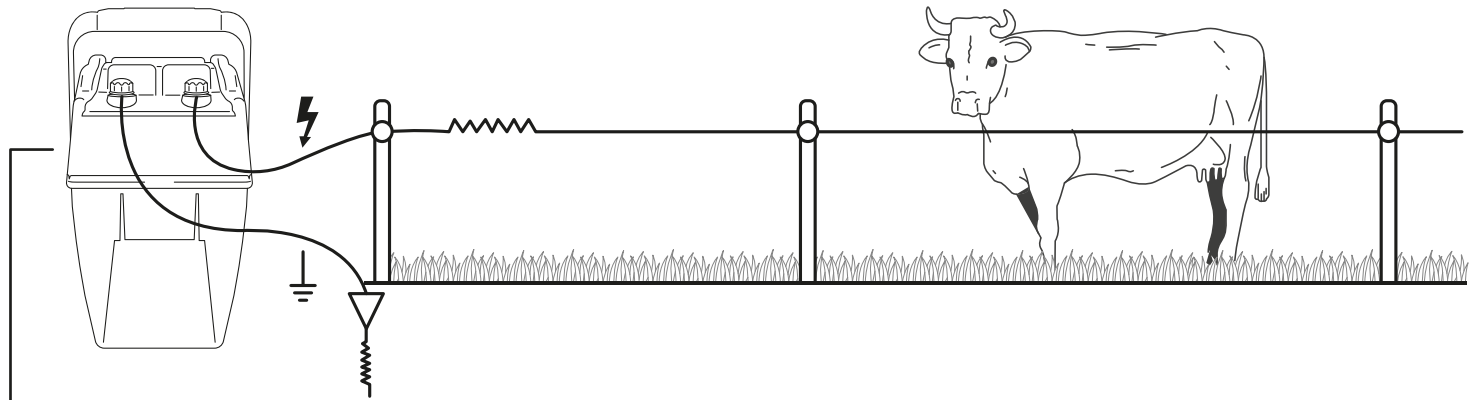

- 1** Cabezal **2** Compartimiento ACU/PILA

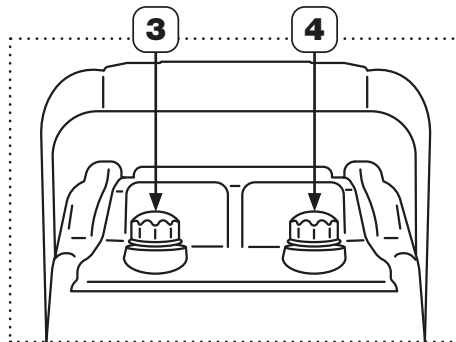

Parte trasera

- 3** Conexión toma de tierra  
**4** Conexión línea de cerca

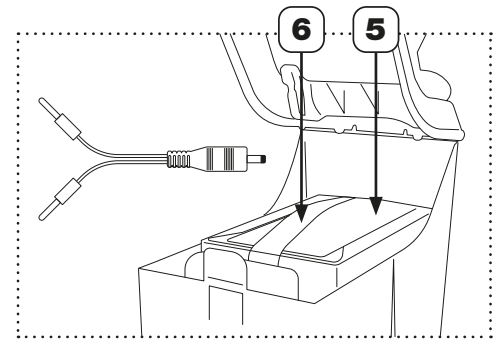

Parte inferior de la tapa

- 5** Conexión sobre pila 9V  
↳ Conectar : hilo rojo sobre rojo / hilo negro sobre negro



**ADVERTENCIA**, si funciona con una batería de 9 V, se debe quitar completamente la etiqueta **6** para que la batería pueda quemarse.

**6**



Posibilidad de funcionar con Batería, prestar atención a la polarización.

**INDICACIONES DE FUNCIONAMIENTO**  **CLOS P-15**

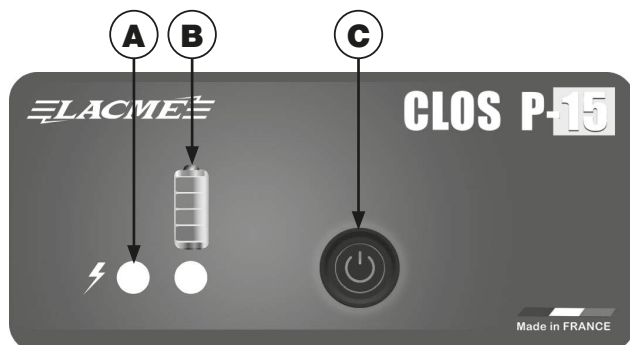

- A** • Testigo de funcionamiento
- B** • Indicador batería baja
- C** • Interruptor Marcha/Parada



Lexan ubicado en la parte superior del poste.

## INDICACIONES DE FUNCIONAMIENTO CLOS P-25 V

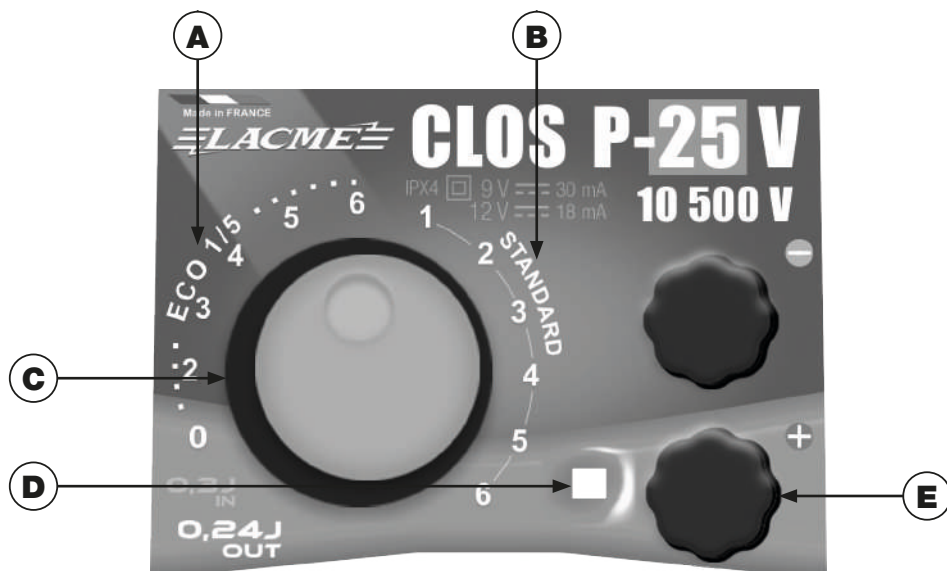

- LED VERDE :**  
OK.
- LED NARANJA :**  
a vigilar.
- LED ROJO :**  
Carga la batería.

- A** • Impulsos Eco 1/5
- B** • Impulsos Estándar
- C** • Potenciómetro  
• Interruptor encendido/apagado
- D** • Indicador de operación  
• Visualización de la carga de la batería
- E** • Conexión panel solar

## INDICACIONES DE FUNCIONAMIENTO CLOS P-25 CLOS P-35

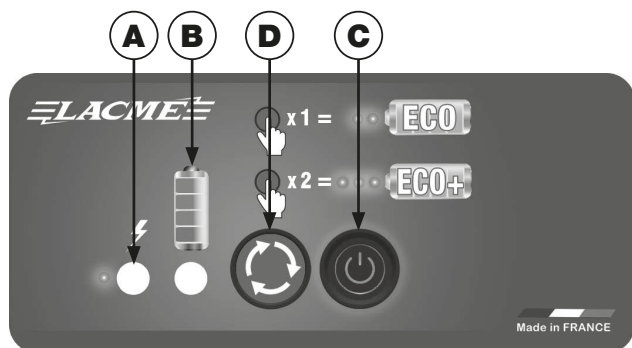

Lexan ubicado en la parte superior del poste.

- A** • Piloto de control
- B** • Indicador batería baja
- C** • Interruptor encendido/apagado
- D** • Modos ÉCO o ÉCO+



**ATENCIÓN,** Para todos los dispositivos, recargar siempre lo antes posible un acumulador en zona roja. En el caso de una pila el re-emplazamiento puede realizarse tras la descarga completa.

## FUNCIONES CLOS P-15



**INTERRUPTOR ENCENDIDO/APAGADO**



**PILOTO DE CONTROL :**

• Encima del dispositivo, hay un piloto de control que informa sobre el buen funcionamiento en cada nuevo impulso.

## FUNCIONES CLOS P-25 V



### VARIADOR DE POTENCIA :

• Un variador de potencia permite regular la potencia en función de las necesidades (tipo de animales, longitud de la cerca, aislamiento, humedad,...) y en particular reducir el consumo en cuanto le período de adiestramiento de los animales se ha acabado.



### MODO ESTÁNDAR O ECO 1/5 :

• Dispone de dos modos de funcionamiento :

**A** El modo estándar

**B** El modo económico : "ECO 1/5" : basta con poner el potenciómetro en uno de los valores del rango de la zona "ECO 1/5". El electrificador repetirá un ciclo de 5 impulsos : le primero será de la potencia determinada por le potenciómetro, los cuatro siguientes serán de potencia reducida.



### INDICADOR DE CARGA DE LA BATERÍA :

• En la parte delantera, un piloto de control de la batería indica la descarga de la alimentación. **Este piloto presenta 3 colores (verde, naranja y rojo).**



### TECNOLOGÍA ACCU PROTECT :

• Cuando la alimentación está demasiado descargada, la tecnología **ACCU PROTECT** cambia automáticamente aparato al modo "ECO 1/5".

## FUNCIONES CLOS P-25 CLOS P-35



### INTERRUPTOR ENCENDIDO/APAGADO



### INDICADOR DE BATERÍA BAJA



### TECNOLOGÍA ACCU PROTECT :

• Cuando la alimentación está demasiado descargada, la tecnología **ACCU PROTECT** cambia automáticamente aparato al modo "ECO".



### MODO ESTÁNDAR, ÉCO O ÉCO+ :



**Primero presión : Económica.**  
(autonomía x2) ; El luz 2 veces parpadeo



**En segundo presión :**  
**Económica +** (autonomía x3) ; El luz 3 veces parpadeo



**Tercera presión : Impulso estándar ;** El luz 1 veces parpadeo

☑ **Clos P-15**

☑ **Clos P-25**

☑ **Clos P-25V**

☑ **Clos P-35**

## Ha appena acquistato un elettrificatore Lacmé, la ringraziamo per la fiducia accordataci.

Secur è un elettrificatore di recinzione ad alimentazione di tipo misto. Può essere alimentato indifferentemente attraverso:

- una pila 9 V
- un accumulatore 12 V (al piombo nel formato idoneo)
- un accumulatore 12 V (al piombo nel formato idoneo) e l'adattatore di rete ( Réf. : 624.000 - opzionale)
- l'adattatore di rete ( Réf. : 624.000 - opzionale) fornito esclusivamente da LACMÉ.

I vari livelli di potenza e le opzioni disponibili per i molteplici modelli sono descritti nel presente manuale d'uso.



**PRUDENZA**, l'utilizzazione congiunta di una batteria o adattatore è pericolosa, quindi proibito.

## ISTRUZIONI IMPORTANTI PER SALVARE :

 Questo logo conferma che è possibile alimentare il recinto con un adattatore a rete.

Solo l'adattatore di rete fornito esclusivamente da LACMÉ ( Réf. : 624.000) è autorizzato opzionalmente su questo elettrificatore. Il collegamento di questo elettrificatore a qualsiasi altro adattatore di rete è rigorosamente vietato per una questione di sicurezza. L'adattatore di rete fornito da LACMÉ non deve essere utilizzato su un elettrificatore fabbricato dalla concorrenza o su un vecchio e/o diverso elettrificatore di LACMÉ non previsto a tale scopo (in caso di dubbi, fare riferimento alle istruzioni allegate al vostro elettrificatore).

La tecnologia utilizzata, detta a "bassa impedenza", permette al recinto di rimanere efficace anche in caso di perdite (erbe che toccano il filo, isolatori rotti, ecc.).

Questo elettrificatore è conforme alle Norme Internazionali di Sicurezza ed è omologato dal Ministero dell'Agricoltura. È venduto con un cavo di collegamento ad "Alta tensione" ed una presa di terra piccola.

## I DIVERSI LIVELLI DI POTENZA :

|                   | Alimentazione | Energia massima<br>(mJ) | Tension crête<br>Vmax<br>(V) | Consumo    |             | Opzione solare<br>consigliata<br>(W) | Impulsi/minuto<br>(i/min) |
|-------------------|---------------|-------------------------|------------------------------|------------|-------------|--------------------------------------|---------------------------|
|                   |               |                         |                              | (mA)<br>9V | (mA)<br>12V |                                      |                           |
| <b>Clos P-15</b>  | 9V* - 12V     | 150                     | 10500                        | 18         | 12          | 3                                    | 40                        |
| <b>Clos P-25</b>  | 9V* - 12V     | 240                     | 10500                        | 30         | 18          | 3                                    | 40                        |
| <b>Clos P-25V</b> | 9V - 12V      | 50 - 240                | 10500                        | 30         | 18          | 3                                    | 40                        |
| <b>Clos P-35</b>  | 9V* - 12V     | 320                     | 10500                        | 36         | 21          | 3                                    | 40                        |

### CLOS P15

Dimensioni : 25 x 19 x 34 cm  
Peso : 3,1 Kg

### CLOS P25/P25V/P354

Dimensioni : 25 x 19 x 34 cm  
Peso : 3,2 Kg

\*Consigliato

## CONSIGLIO :

|                   | Animali            | Lunghezza recinto (km) con vegetazione : |       |       |
|-------------------|--------------------|--|-------|-------|
|                   |                    | Scarsa                                   | Media | Folta |
| <b>Clos P-15</b>  | Sensibili, docili  | 2  | 0,5   | -     |
| <b>Clos P-25</b>  | Docili, addestrati | 3  | 1     | -     |
| <b>Clos P-25V</b> | Docili, addestrati | 3  | 1     | -     |
| <b>Clos P-35</b>  | Docili, addestrati | 4  | 1,5   | 0,5   |

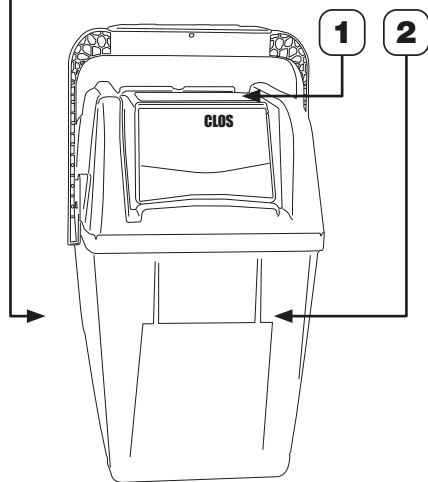
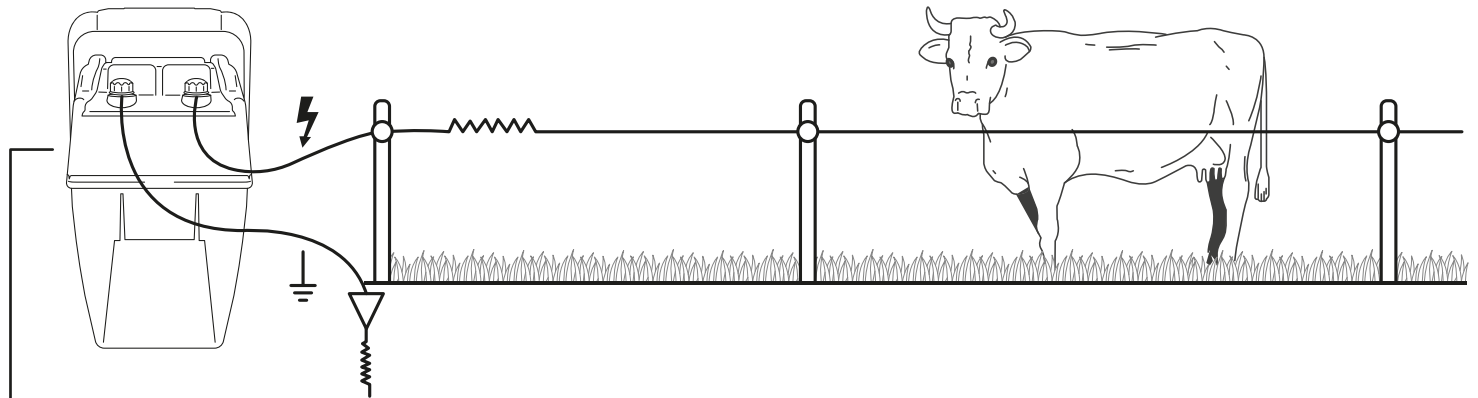

- 1** Testa
- 2** Vano porta batteria

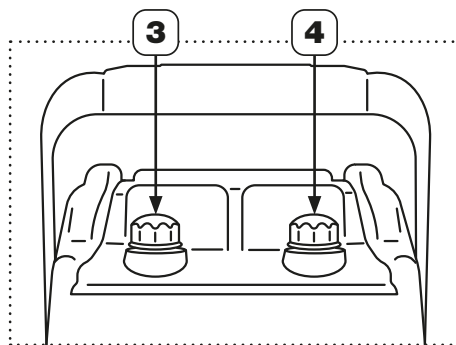

Facciata posteriore

- 3** Connessione collegamento a terra
- 4** Connessione filo di recinzione

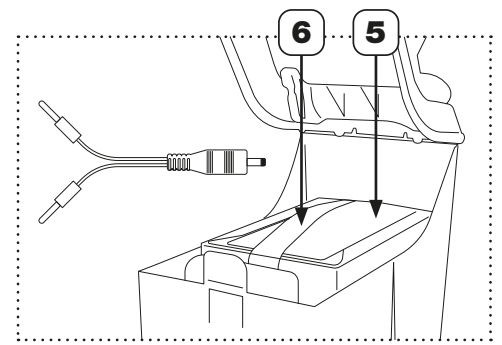

Parte inferiore del coperchio

- 5** Connessione sulla pila 9V  
↳ Collegare : filo rosso su rosso / filo nero su nero



**ATTENZIONE**, se alimentato con batteria da 9V l'etichetta **6** deve essere completamente rimossa in modo che la batteria possa bruciare

**6**



Possibilità di alimentazione a batteria, assicurarsi di rispettare la polarizzazione.

**INDICAZIONI OPERATIVE** ☑ **CLOS P-15**

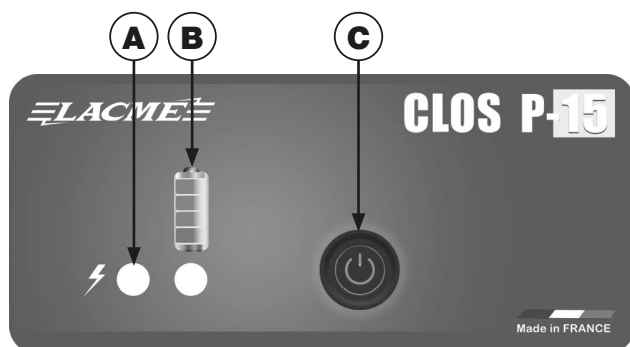

Lexan situato in cima al palo

- A** • Visualizzazione della carica della batteria
- B** • Indicatore batteria scarica
- C** • Interruttore ON/OFF



## INDICAZIONI OPERATIVE CLOS P-25 V

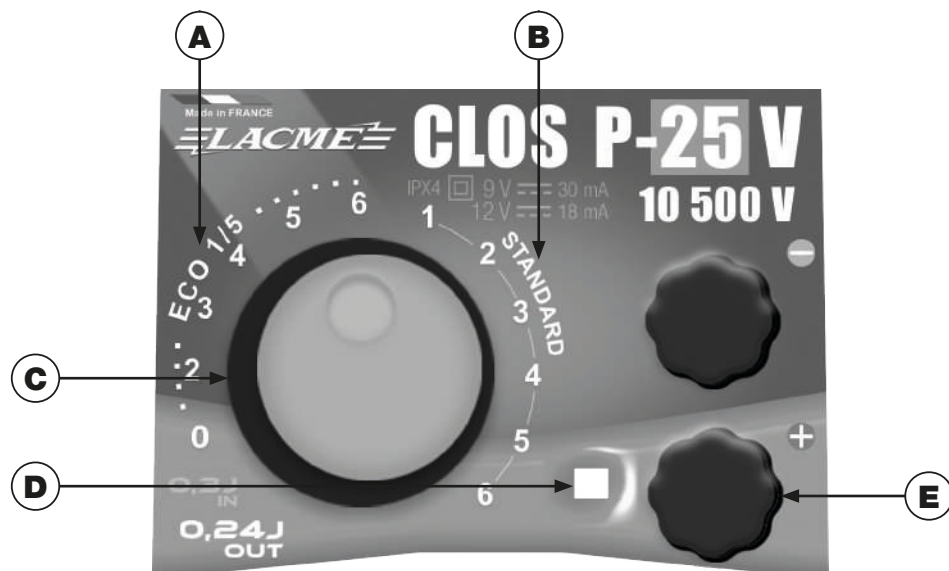

- ✓ **LED VERDE** : OK.
- ✓ **LED ARANCIONE** : monitorare.
- ✓ **LED ROSSO** : caricare la batteria.

- A** • Impulsi Eco 1/5
- B** • Impulsi standard
- C** • Variatore di potenza  
• Acceso/Spento
- D** • Indicatore di funzionamento  
• Visualizzazione della carica della batteria
- E** • Presa pannello solare

## INDICAZIONI OPERATIVE CLOS P-25 CLOS P-35

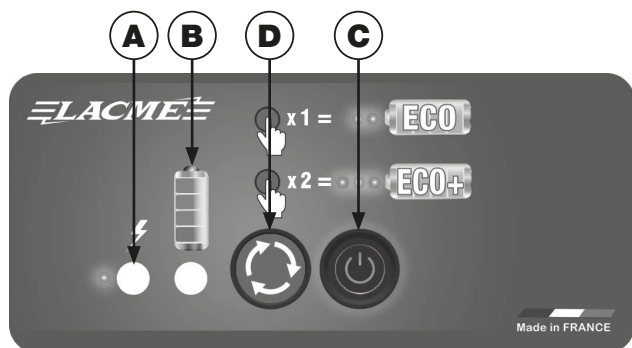

*Lexan situato in cima al palo*

- A** • Indicatore di funzionamento
- B** • Indicatore batteria scarica
- C** • Acceso/Spento
- D** • Modo ÉCO o ÉCO+



**ATTENZIONE**, Per tutti i dispositivi, Ricaricare sempre, appena possibile, un accumulatore nella zona rossa. Per la sostituzione di una pila, si può attendere che sia completamente scarica.

## FUNZIONI CLOS P-15



**INTERRUTTORE ON/OFF**

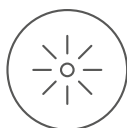

**PILOTA DI CONTROLLO :**

• Sopra il dispositivo, E' presente un pilota di controllo che ad ogni nuovo impulso vi informa del suo corretto funzionamento.

## FUNZIONI CLOS P-25 V



### VARIATORE DI IMPULSO :

• Un variatore permette di regolare la potenza a seconda delle esigenze (tipo di animale, lunghezza del recinto, isolamento, umidità, ecc.) ed in particolare di ridurre il consumo, quando il periodo di addestramento degli animali è terminato.



### MODO STANDARD O "ECO 1/5" :

• Esistono due modi di funzionamento :

**A** Il modo standard

**B** Il modo economico : "ECO 1/5", : basta di sistemare il variatore su una dei valore aera corrispondente a la zona "ECO 1/5". Il recinto ripete un ciclo di 5 impulsi : la prima è di potenza determinata per il variatore, le 4 altri sono di potenza ridotta.



### SPIA CARICA BATTERIA :

• Sul lato anteriore, una spia di controllo Batteria indica la condizione di esaurimento della carica. **Questa spia luminosa ha 3 colori (verde, arancione, rosso).**



### DISPOSITIVO ACCU PROTECT :

• Quando l'alimentazione è troppo scarica, il dispositivo **ACCU PROTECT** fa passare automaticamente l'apparecchio alla modalità "ECO 1/5".

## FUNZIONI CLOS P-25 CLOS P-35



### INTERRUTTORE ON/OFF



### INDICATORE DI BATTERIA SCARICA



### DISPOSITIVO ACCU PROTECT :

• Quando l'alimentazione è troppo scarica, il dispositivo **ACCU PROTECT** fa passare automaticamente l'apparecchio alla modalità "ECO 1/5".



### MODI STANDARD, ÉCO O ÉCO+ :



**Pressione iniziale : Economia,**  
(autonomia x2) ; La luce ha lampeggiato 2 volte



**Seconda pressione : Economia +,**  
(autonomia x3) ; La luce ha lampeggiato 3 volte

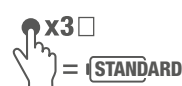

**Terza pressione : impulsi standard ;** La luce ha lampeggiato 1 volta

**Clos P-15**
 **Clos P-25**
 **Clos P-25V**
 **Clos P-35**

### **Acabou de comprar um eletrificador Lacmé e gostaríamos de agradecer a sua confiança.**

Tem uma fonte de alimentação mista (Dual) e pode ser alimentado por :

- uma pilha de 9 V
- uma bateria de 9V (de chumbo no formato adequado)
- uma bateria de 9V (de chumbo no formato adequado) e o adaptador de rede (Ref.: 624.000 - opcional)
- o adaptador de rede (opcional) fornecido exclusivamente pela LACMÉ.

Os diferentes níveis de potência e opções, consoante os modelos, são descritos nestas instruções.



**AVISO**, uma pilha nunca deve ser conectada quando o dispositivo for alimentado por um adaptador CA ou carregador.

### **INSTRUÇÕES IMPORTANTES PARA ECONOMIZAR :**

Este logótipo confirma que pode alimentar o seu eletrificador com um adaptador de rede.

Apenas o adaptador de rede fornecido exclusivamente pela LACMÉ (Ref.: 624.000) é autorizado para este eletrificador.

Por razões de segurança, é estritamente proibido ligar este eletrificador a qualquer outro adaptador de rede elétrica. O adaptador de rede fornecido pela LACME não deve ser utilizado num eletrificador de um concorrente ou num eletrificador antigo e/ou noutra eletrificador LACME que não tenha sido concebido para este fim (em caso de dúvida, consulte as instruções fornecidas com o seu eletrificador).

É fornecido com um fio de ligação de "Alta Tensão" e uma pequena ligação à terra.

Este eletrificador está em conformidade com as Normas Internacionais de Segurança e é aprovado pelo Ministério da Agricultura.

### **OS DIFERENTES NÍVEIS DE POTÊNCIA :**

|                   | Fonte de energia | Energia máxima<br>(mJ) | Tensão de pico<br>Vmax<br>(V) | Consumo | Opção solar<br>recomendada | Pulsos/minute<br>(W) | Impulsions/<br>minute<br>(i/min) |
|-------------------|------------------|------------------------|-------------------------------|---------|----------------------------|----------------------|----------------------------------|
|                   |                  |                        |                               | (mA)    | (mA)                       |                      |                                  |
|                   |                  |                        |                               | 9V      | 12V                        |                      |                                  |
| <b>Clos P-15</b>  | 9V* - 12V        | 150                    | 10500                         | 18      | 12                         | 3                    | 40                               |
| <b>Clos P-25</b>  | 9V* - 12V        | 240                    | 10500                         | 30      | 18                         | 3                    | 40                               |
| <b>Clos P-25V</b> | 9V - 12V         | 50 - 240               | 10500                         | 30      | 18                         | 3                    | 40                               |
| <b>Clos P-35</b>  | 9V* - 12V        | 320                    | 10500                         | 36      | 21                         | 3                    | 40                               |

#### **CLOS P15**

Dimensões : 25 x 19 x 34 cm

Peso : 3,1 Kg

#### **CLOS P25/P25V/P354**

Dimensões : 25 x 19 x 34 cm

Peso : 3,2 Kg

*\*Recomendado*

### **CONSELHOS :**

|                   | Animais             | Comprimento da vedação (em km) com vegetação : |       |      |
|-------------------|---------------------|--|-------|------|
|                   |                     | Baixa  | Média | Alta |
| <b>Clos P-15</b>  | Sensíveis / dóceis  | 2  | 0,5   | -    |
| <b>Clos P-25</b>  | Fáceis / adestrados | 3  | 1     | -    |
| <b>Clos P-25V</b> | Fáceis / adestrados | 3  | 1     | -    |
| <b>Clos P-35</b>  | Fáceis / adestrados | 4  | 1,5   | 0,5  |

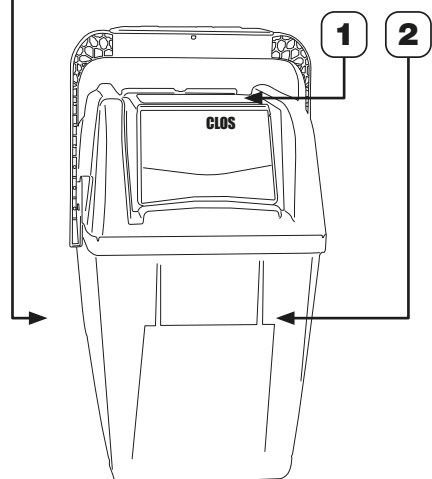
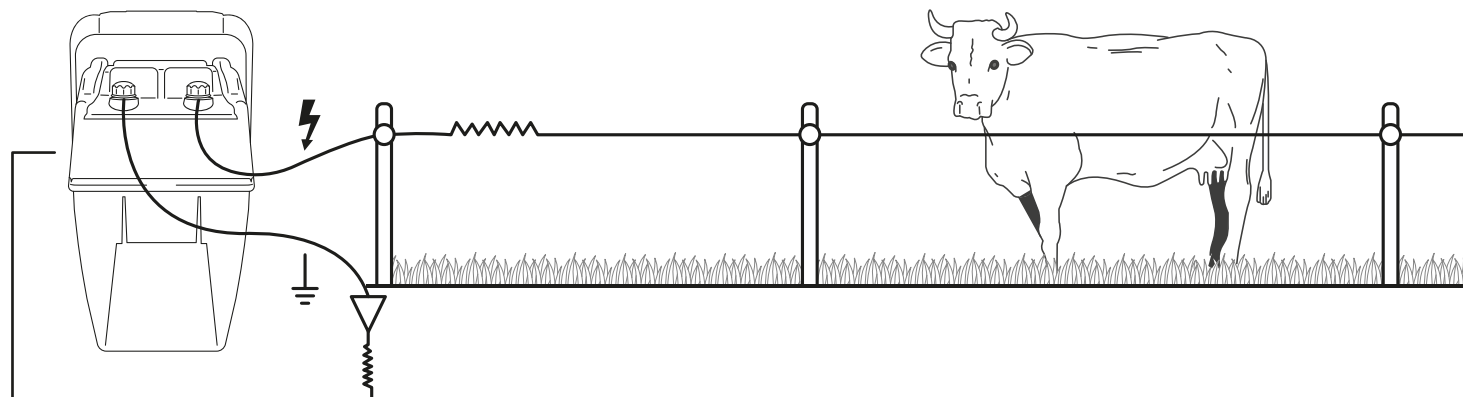

- 1** Cabeça    **2** Caixa bateria-pilha

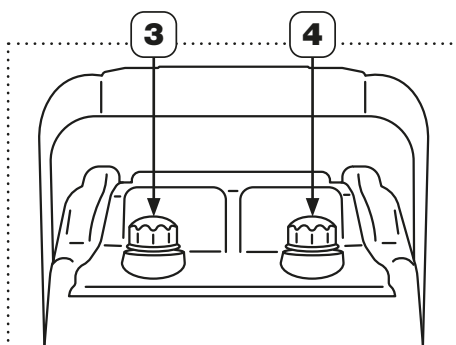

Parte traseira do dispositivo

- 3** Ligação à terra  
**4** Ligação ao arame de vedação

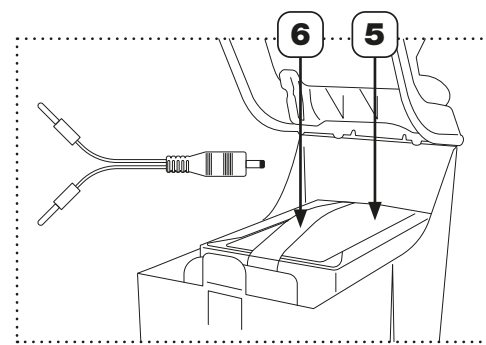

Parte inferior da tampa

- 5** Conexão à **pilha 9V**  
↳ Conecte o fio vermelho em linha vermelha e preto em preto



**ATENÇÃO**, se alimentado por bateria de 9V a etiqueta **6** deve ser totalmente removida para que a bateria possa queimar.

**6**



Alimentado por bateria possível, certifique-se de respeitar a polarização.

**INDICAÇÕES DE FUNCIONAMENTO**

**CLOS P-15**

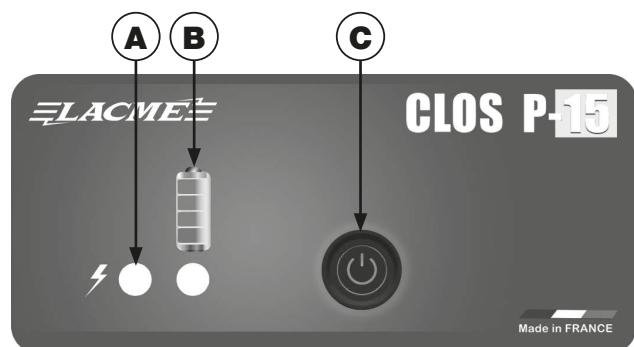

- A** • LED indicador de funcionamento
- B** • Indicador bateria fraca
- C** • Interruptor ligado/desligado



Lexan localizado no topo do poste

## INDICAÇÕES DE FUNCIONAMENTO

✓ CLOS P-25 V

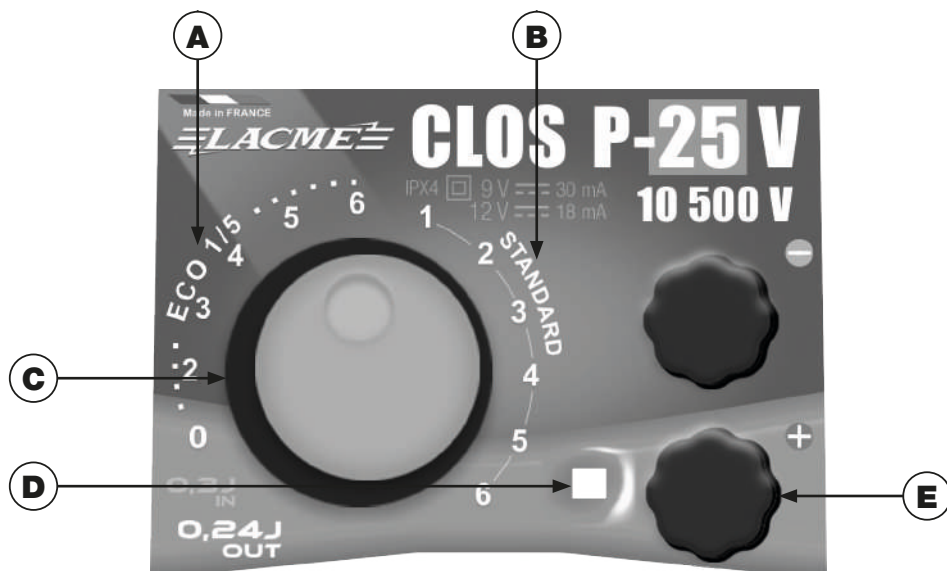

- ✓ LED VERDE : OK.
- ✓ LED LARANJA : assistir.
- ✓ LED VERMELHO : carregar a bateria.

**A** • Impulsos Eco 1/5

**B** • Impulsos standard

**C** • Variador de potência  
• Ligado/  
Desligado

**D** • LED indicador de funcionamento  
• Indicador de carga da bateria

**E** • Ligação ao painel solar

## INDICAÇÕES DE FUNCIONAMENTO

✓ CLOS P-25

✓ CLOS P-35

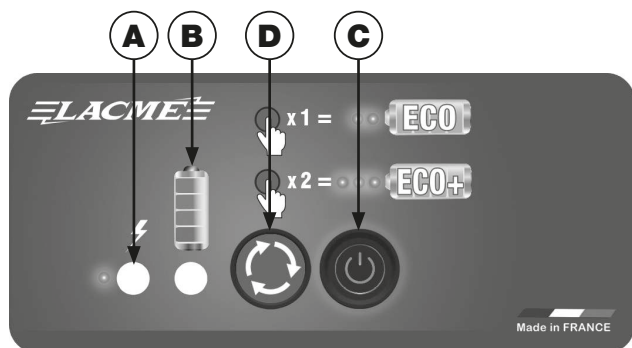

Lexan localizado no topo do poste

**A** • LED indicador de funcionamento

**B** • Indicador bateria fraca

**C** • Interruptor ligado/desligado

**D** • Modas ÉCO ou ÉCO+



**ATENÇÃO**, para todos os eletrificador, Recarregar sempre uma bateria em zona vermelha o mais rapidamente possível. No caso de uma pilha, a troca pode esperar até que esta esteja completamente descarregada.

## FUNÇÕES

✓ CLOS P-15



**INTERRUPTOR  
LIGADO/DESLIGADO**



**LUZ INDICADORA :**

• Uma luz indicadora no capo indica se o dispositivo está a funcionar correctamente a cada impulso.

## FUNÇÕES CLOS P-25 V



### VARIADOR DE POTÊNCIA :

• O variador permite ajustar a potência em função das necessidades (tipo de animais, comprimento da vedação, isolamento, humidade, etc.), e, em particular, reduzir o consumo assim que terminar o período de treino dos animais.



### MODAS STANDARD OU ECO 1/5 :

• Existem dois modos de funcionamento :

**A** O modo padrão (Standard)

**B** O modo económico : "ECO 1/5": basta definir o variador para um dos valores no intervalo correspondente à zona "ECO 1/5". O eletrificador repete um ciclo de 5 impulsos: o primeiro é à potência definida pelo variador, os outros 4 são à potência reduzida.



### INDICADOR DE CARGA DA PILHA/BATERIA :

• Uma luz indicadora de bateria na parte frontal indica quando a fonte de alimentação está descarregada. **Este indicador luminoso tem 3 cores (verde, laranja, vermelho).**



### TECNOLOGIA "ACCU PROTECT" (PROTEÇÃO ACCU) :

• Quando a fonte de alimentação está muito descarregada, tecnologia **ACCU PROTECT** muda automaticamente o dispositivo para "ECO 1/5" (modo económico).

## FUNÇÕES CLOS P-25 CLOS P-35



### INTERRUPTOR LIGADO/DESLIGADO



### INDICADOR DE BATERIA FRACA



### TECNOLOGIA "ACCU PROTECT" (PROTEÇÃO ACCU) :

• Quando a fonte de alimentação está muito descarregada, tecnologia **ACCU PROTECT** muda automaticamente o dispositivo para "ECO 1/5" (modo económico).



### MODAS STANDARD, ÉCO OU ÉCO+ :



**Primeiro pressão** : Mudança para modo **ECO** (autonomia x2) ; O LED operacional pisca 2 vezes



**Segunda pressão** : Mudança para modo **ECO+** (autonomia x3) ; O LED operacional pisca 3 vezes

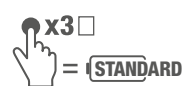

**Terceira pressão** : Mude para o modo **PADRÃO** ; O LED operacional pisca 1 vez

Retrouvez-nous sur  
***www.Lacmé.com***

*Le tout nouveau site Lacmé, spécialement conçu pour vous !*

---



**LACMÉ**